

MicroSmart FC6A Plus PLC

CPU Modules



PRODUCT DESCRIPTION

This next-generation IDEC MicroSmart FC6A Plus PLC performs beyond micro PLC limits. With its 2,060 I/O capacity, it can control large machines or entire small-scale manufacturing facilities, providing more capabilities for the most demanding applications.

KEY FEATURES

- Dual Ethernet ports
- iOS and Android app
- Maximum 2,060 digital I/O
- Maximum 511 analog I/O
- Bluetooth communication

FC6A PLUS CPU MODULES

High-speed Counter & Pulse Output	Power	Input	Output	Interface	I/O Points	Part No.
<ul style="list-style-type: none"> • High-speed counter • Maximum input frequency: 100kHz • Pulse output (*1) • Maximum output frequency: 100kHz 	24V DC	24V DC (Sink/Source)	Relay Output 2A (240V AC-2A, 30V DC-2A)	Port 1 (USB) Port 2 (Ethernet) Port 3 (Ethernet)	16 points (8/8)	FC6A-D16R1CEE
			Transistor Source Output 0.5A			FC6A-D16P1CEE
			Transistor Sink Output 0.5A			FC6A-D16K1CEE
			Transistor Source Output 0.1A		32 points (16/16)	FC6A-D32P3CEE
			Transistor Sink Output 0.1A			FC6A-D32K3CEE

SPECIFICATIONS

General Specifications

Part No.	FC6A-D16R1CEE FC6A-D16P1CEE FC6A-D16K1CEE	FC6A-D32P3CEE FC6A-D32K3CEE
Rated Power Voltage	24V DC	
Allowable Voltage Range	20.4 to 28.8V DC (including ripple)	
Maximum Power Consumption (CPU module)	FC6A-D16R1CEE: 2.88W (24V DC) FC6A-D16P1CEE: 2.88W (24V DC) FC6A-D16K1CEE: 2.88W (24V DC) FC6A-D32P3CEE: 3.36W (24V DC) FC6A-D32K3CEE: 3.36W (24V DC)	
Inrush Current	35A maximum	
Allowable Momentary Power Interruption	10ms (at rated voltage)	
Operating Temperature	-10 to +55°C (no freezing)	
Storage Temperature	-25 to +70°C (no freezing)	
Relative Humidity	Level RH1 (IEC 61131-2) 10 to 95% (no condensation)	
Altitude	Operation: 0 to 2,000m, 795 to 1,013hPa, Transport: 0 to 3,000m, 701 to 1,013hPa	
Pollution Degree	2 (IEC 60664-1)	
Corrosion Immunity	Free from corrosive gases	
Dielectric Strength	Between power and FE terminals: 500V AC, 1 minute Between transistor output and FE terminals: 500V AC, 1 minute Between power and input terminals: 500V AC, 1 minute Between power and relay output terminals: 2,300V AC, 1 minute Between input and relay output terminals: 2,300V AC, 1 minute	Between input and FE terminals: 500V AC, 1 minute Between relay output and FE terminals: 2,300V AC, 1 minute Between power and transistor output terminals: 500V AC, 1 minute Between input and transistor output terminals: 500V AC, 1 minute



Class Div2
Hazardous
Location



GENERAL SPECIFICATIONS (CON'T)

Insulation Resistance	Between power and FE terminals: 100MΩ or higher (500V DC megger)	Between input and FE terminals: 100MΩ or higher (500V DC megger)
	Between transistor output and FE terminals: 100MΩ or higher (500V DC megger)	Between relay output and FE terminals: 100MΩ or higher (500V DC megger)
Noise Resistance	Between power and input terminals: 100MΩ or higher (500V DC megger)	Between power and transistor output terminals: 100 MΩ or higher (500V DC megger)
	Between power and relay output terminals: 100 MΩ or higher (500V DC megger)	Between input and transistor output terminals: 100 MΩ or higher (500V DC megger)
Vibration Resistance	AC/DC power terminals: 1kV, 50ns to 1μs I/O terminals (coupling clamp): 1.5kV, 50ns to 1μs coupling adapter	
Shock Resistance	5 to 8.4Hz amplitude 3.5mm 8.4 to 150Hz acceleration 9.8m/s ² (1G), 2 hours per axis on each of three mutually perpendicular axes (IEC 61131-2)	
Degree of Protection	IP20 (IEC 60529)	
Power Supply Wire	UL1007 AWG24-16, UL2464 AWG24-16, UL1015 AWG20-16	
Grounding Wire	UL1007 AWG16	
Ground	D-type ground (Class 3 ground)	
Mounting	DIN rail or panel mounting	
Weight (approx.)	FC6A-D16R1CEE: 290g	FC6A-D32P3CEE: 255g
	FC6A-D16P1CEE: 275g	FC6A-D32K3CEE: 255g
	FC6A-D16K1CEE: 275g	

FUNCTION SPECIFICATIONS

Part No.	FC6A-D16R1CEE FC6A-D16P1CEE (*4) FC6A-D16K1CEE (*4)	FC6A-D32P3CEE (*4) FC6A-D32K3CEE (*4)
Control System	Stored program system	
Instruction Words	Basic	42
	Advanced	130
Program Capacity (*1)	800KB (100,000 steps)	
User Program Storage	Serial Flash Memory (100,000 times rewritable)	
Processing Time	Basic Instruction	21μs/1,000 steps
	END Processing (*2)	1ms maximum
I/O Points	Input	8 points 16 points
	Output	8 points 16 points
Expandable Modules	7 modules (*3)	
Expandable I/O Points with Expansion Modules	224 points	
Expandable Modules with Unibody Type Expansion Modules	8 modules	
Expandable I/O Points with Unibody Type Expansion Modules	256 points	
Expandable Modules with Separate Type Expansion Modules (*5)	63 modules (separate type master: 1 module maximum, separate type slave: 10 modules maximum)	
Expandable I/O Points with Separate Type Expansion Modules (*5)	2,016 points	
Internal Relay	15,400 points	
Special Internal Relay	1,600 points	
Shift Register	256 points	
Data Register	60,000 points	
Non-Retentive Data Register	200,000 points	
Special Data Register	900 points	
Counter	512 points	
Timer (1ms, 10ms, 100ms, 1s)	2,000 points	
Clock	Clock accuracy: ±30 sec/month (typical) at 25°C	
RAM Backup	Backup Data	Internal relay, shift register, counter, data register, timer, special data register, special internal relay, clock data
	Battery	Lithium primary battery (BR2032)
	Battery Life	Approx. 4 years
	Replaceability	Possible
Self-diagnostic Function	Keep data, user program sum check (serial flash memory), user program sum check (RAM), timer/counter preset value sum check, user program syntax check, user program execution check, WDT check, user program write check, power failure, clock error, data link connection check, I/O bus initialization check	
Input Filter	0 ms (without filter), 3 to 15ms (selectable in increments of 1ms) I14, I15, I16, I17: 3ms	
Catch Input/Interrupt Input	Six inputs I0, I1, I3, I4, I6, I7 (Minimum turn on pulse width: 5μs max./Minimum turn off pulse width: 5μs max.)	

USB PORT SPECIFICATIONS

USB Type	USB mini-B
USB Standard	USB 2.0
Isolation	Not isolated from the internal circuit
Communication Function	Maintenance communication to PC

ETHERNET PORT 1 SPECIFICATIONS

Communication Type	IEEE802.3 compliant
Communication Speed	10BASE-T, 100BASE-TX
Connector	RJ45
Cable	CAT.5STP
Maximum Cable Length	100m
Isolation	Pulse trans isolation
Communication Function	Maintenance communication (server), user communication (server/client), user communication UDP, Modbus TCP (server/client), Email, Web Server, PING, SNT, FTP server/client

ETHERNET PORT 2 SPECIFICATIONS

Communication Type	IEEE802.3 compliant
Communication Speed	10BASE-T, 100BASE-TX
Connector	RJ45
Cable	CAT.5STP
Maximum Cable Length	100m
Isolation	Pulse trans isolation
Communication Function	Maintenance communication (server), user communication (server/client), user communication UDP, Modbus TCP (server/client), PING

FUNCTION SPECIFICATIONS (CON'T)

High-speed Counter	Maximum Counting Frequency and High-speed Counter Points	Total 6 points Single/two-phase selectable: 100kHz (single-phase: 6 points, two-phase: 3 points)
	Counting Range	0 to 4,294,967,295 (32 bits)
	Operation Mode	Rotary encoder mode, adding counter mode, frequency measurement mode
Analog Potentiometer	Quantity	1 point
	Data Range	0 to 1,000
Analog Voltage Input	Quantity	1 point
	Input Voltage Range	0 to 10V
	Input Impedance	Approx. 100K Ω
Pulse Output (transistor output model only)	Digital Resolution	Approx. 4,000 steps (12 bits)
	Quantity	4 points
	Maximum Output Pulse Frequency	Q0, Q2, Q4, Q6: 100kHz
USB Port	Reversible Control	Single-pulse output mode: 4 axis (Q0-Q7), Dual-pulse output mode: 4 axis (Q0-Q7)
	PWM Output	Duty cycle 0.1 to 100.0% (increments of 0.1%), Output pulse frequency 15 to 5,000 Hz (increments of 1 Hz): 4 points (Q0, Q2, Q4, Q6) (Adjust 5 μ s minimum as ON time and 15 μ s minimum as OFF time.)
Ethernet Port 1	Maintenance communication (server), user communication TCP (server/client), user communication UDP, Modbus TCP (server/client), Email, Web Server, PING, SNMP, FTP server/client	
Ethernet Port 2	Maintenance communication (server), user communication TCP (server/client), user communication UDP, Modbus TCP (server/client), PING	
Cartridge (option)	Two cartridges can be added (when using FC6A-HPH1)/One cartridge can be added (when using FC6A-PH1)	
SD Card Slot	Embedded	
HMI Module (option)	Yes	

*1: 1 step equals 8 bytes.

*2: Not including expansion I/O service time, counter timer processing time, data link processing time, and interrupt processing time.

*3: A maximum of 5 modules can be connected when using the expansion interface module separate type master.

*4: Transistor output model

*5: Communication module cannot be connected.

INPUT SPECIFICATIONS

Part No.	FC6A-D16R1CEE FC6A-D16P1CEE FC6A-D16K1CEE	FC6A-D32P3CEE FC6A-D32K3CEE
Input Points	8 (8/1 common)	16 (16/1 common)
Rated Input Voltage	24V DC: 24V DC sink/source input signal	
Input Voltage Range	0 to 28.8V DC	
Rated Input Current	High speed input port 5mA/pt, middle/normal speed input port 7mA/pt	
Input Impedance	High speed input port 4.9k Ω , middle/normal speed input port: 3.4k Ω	
Input Delay	Turn ON Time	High speed input port: 5 μ s + filter value Middle speed input port: 35 μ s + filter value Normal speed input port: 35 μ s + filter value
	Turn OFF Time	High speed input port: 5 μ s + filter value Middle speed input port: 35 μ s + filter value Normal speed input port: 100 μ s + filter value
Isolation	Between input terminals: Not isolated Internal circuit: Optocoupler-isolated	
Input Type	Type1 (IEC 61131-2)	
External Load for I/O Interconnection	Not needed	
Signal Determination Method	Static	
Effect of Improper Input Connection	Both sinking and sourcing input signals can be connected, therefore reverse connection does not cause damage. If any input exceeding the rated value is applied, permanent damage may be caused.	
Cable Length	3m in compliance with electromagnetic immunity	
Connector	Insertion Durability	100 times minimum
	Applicable Ferrule	1-wire: AI 0.5-8 WH (Phoenix Contact) 2-wire: AI-TWIN 2x0.5-8 WH (Phoenix Contact)

RELAY OUTPUT SPECIFICATIONS

Part No.	FC6A-D16R1CEE	
Relay Output Points	8	
Output Points per Common Line	COM1	4
	COM2	4
Output Type	1NO	
Maximum Load Current	Per Point	2A
	Per Common	COM1: 7A COM2: 7A
Minimum Switching Load	1mA/5V DC (reference value)	
Initial Contact Resistance	30m Ω maximum	

RELAY OUTPUT SPECIFICATIONS (CON'T)

Electrical Life		100,000 operations minimum (rated resistive load 1,800 operations/hour)
Mechanical Life		20,000,000 operations minimum (no load 18,000 operations/hour)
Rated Load		Resistive load: 240V AC 2A, 30V DC 2A Inductive load: 240V AC 2A (cos $\phi = 0.4$), 30V DC 2A (L/R = 7 ms)
Connector	Insertion/Removal Durability	100 times minimum
	Applicable Ferrule	1-wire: AI 0.5-8 WH (Phoenix Contact) 2-wire: AI-TWIN 2x0.5-8 WH (Phoenix Contact)

TRANSISTOR OUTPUT SPECIFICATIONS

Part No.		FC6A-C16P1CEE FC6A-C16K1CEE	FC6A-D32P3CEE FC6A-D32K3CEE
Transistor Output Points		8 (8/1 common)	16 (16/1 common)
Output Type	Transistor Sink	FC6A-D16K1CEE/FC6A-D32K3CEE	
	Transistor Source	FC6A-D16P1CEE/FC6A-D32P3CEE	
Rated Load Voltage		24V DC	
Voltage Tolerance		19.2 to 28.8V DC	
Rated Load Current	Per Point	0.5A	0.1A
	Per Common	4.0A	1.6A
Output Delay	Turn ON Time	High speed input port: 5 μ s Normal speed input port: 300 μ s	
	Turn OFF Time	High speed input port: 5 μ s Normal speed input port: 300 μ s	
Isolation		Between output terminal and Internal circuit: Optocoupler-isolated Between output terminals: Not isolated	
Voltage Drop (ON Voltage)		1V max (voltage between COM and output terminal when output is on.)	
Inrush Current		1A	0.2A
Leakage Current		0.1mA maximum	
Clamping Voltage		39V \pm 1V	
Maximum Lamp Load		12W	2.4W
Inductive Load		L/R=10ms (28.8V DC, 1Hz)	
Overcurrent Protection		Transistor Sink Output: No Transistor Source Output: Overcurrent is detected by current limit resistance. (*1)	
External Current Draw		100mA maximum, 24V DC (power voltage at the +V terminal, -V terminal at source)	
Connector	Insertion Durability	100 times minimum	
	Applicable Ferrule	1-wire: AI 0.5-8 WH (Phoenix Contact) 2-wire: AI-TWIN 2x0.5-8 WH (Phoenix Contact)	—

*1: This overcurrent signals consist of one signal per 4 point outputs. When microprocessor gets this overcurrent signal by interrupt input, microprocessor turns off 4pt outputs of this category at fixed time (approx. 1sec).

DIMENSIONS (mm)

Plus CPU Modules

FC6A-D16R1CEE
FC6A-D16K1CEE
FC6A-D16P1CEE

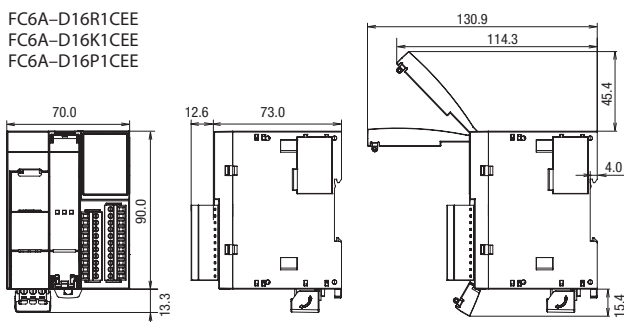

FC6A-D32K3CEE
FC6A-D32P3CEE

