

LRGSC-Series



The LRGSC-Series Super Curvette rocker switches offer double pole circuitry in an illuminated package. These switches can handle up to 125 amp peak inrush current and can accommodate a wide range of panel cutouts due to the patented mounting ear construction. International ratings are available up to 20 amps.

Specifications

- Certifications*: UL, CSA, VDE
- Dielectric Strength: 1,000 V (minimum)
- Insulation Resistance: 100 Megohms (minimum)
- Base Material: Nylon
- Actuator Material: Nylon/Polycarbonate

* Due to ongoing technological advances, consult factory for certification specifics.

Dimensional Specifications: in. [mm]

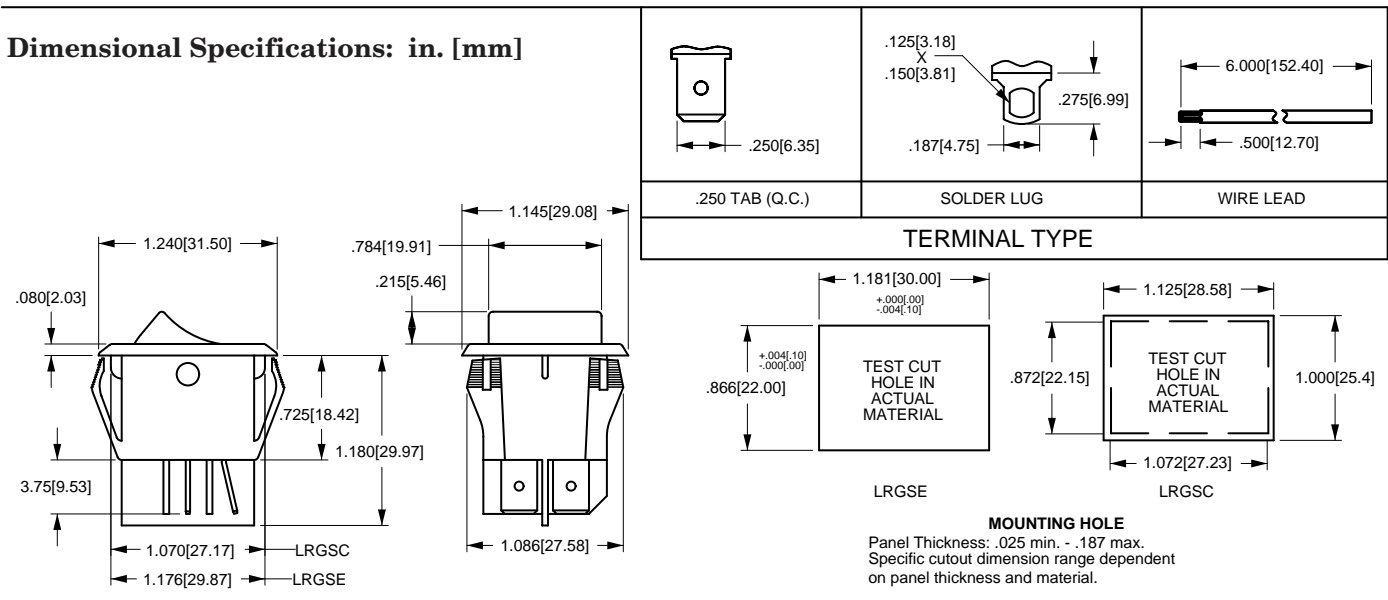

LRGSC K 71 1 - R - S - B - 0 / 250N

SERIES	RATING ¹	ACTUATOR STYLE	BASE COLOR ²	LAMP VOLTAGE
LRGSC STANDARD BASE	22 15A 250VAC 20A 125VAC	R TRANSLUCENT ROCKER	B BLACK	006V 6 VOLTS/ INCANDESCENT ⁵
LRGSE EUROPEAN BASE	16(6)A 125VAC T85	C CLEAR ROCKER	W WHITE	012V 12 VOLTS/ INCANDESCENT ⁵
	51 LOW VOLTAGE FOR 6, 12, 18 & 24 VOLT LAMPS		ROCKER FACE IMPRINTED LEGEND⁴	018V 18 VOLTS/ INCANDESCENT ⁵
	61 15A 250VAC 20A 125VAC	COLOR		024V 24 VOLTS/ INCANDESCENT ⁵
	71 15A 250VAC 20A 125VAC 16(6)A 250VAC T85	TRANSLUCENT		125N 125 VOLTS/ NEON
CIRCUIT		A APRICOT (amber)	0 NO LEGEND	250N 250 VOLTS/ NEON
K OFF-NONE-ON DOUBLE POLE		C COCONUT (white)	A OFF-ON (VERTICAL)	
	TERMINATION	L LIME (green)	B OFF-ON (HORIZONTAL)	
	0 SOLDER LUG	S STRAWBERRY (red)	D O-I (HORIZONTAL)	
	1 .250TAB (QC)	W WATERMELON (pale red)	E O-I (VERTICAL)	
	5 WIRE LEAD		F ON-OFF (VERTICAL)	
		CLEAR	G ON-OFF (HORIZONTAL)	
		A AMBER		
		B BLUE ³		
		C CLEAR		
		G GREEN		
		R RED		

NOTES:

Shading indicates standard configurations.

Panel Cut-Out Recommendations: For sheet metal panels, switch must enter panel in same direction as the punch. (Burr on bottom.) Test cut hole in actual material.

1 Rating Code 22 must use 125V neon lamp. Rating code 71 must use 250V neon lamp.

2 Custom colors are available. Consult factory.

3 Not available with 125VAC, 250VAC neon lamp.

4 White is standard with dark actuators; black is standard with light actuators.

5 Incandescent lamps must specify rating code 51.